

SECTION A-A

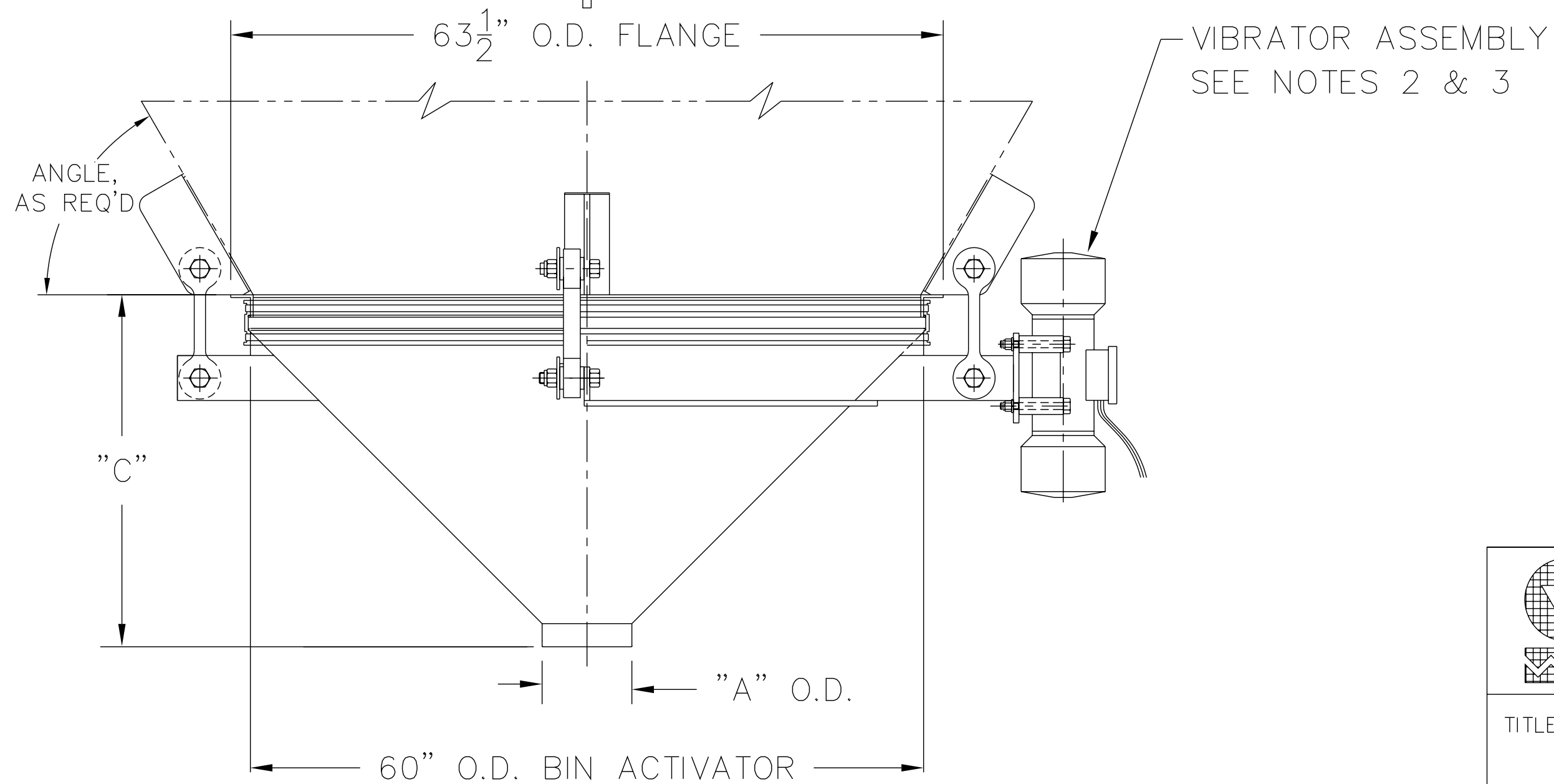

"A" O.D.	"C"
8" O.D.	31 3/8"
10" O.D.	30 3/8"
12" O.D.	29 3/8"
14" O.D.	28 3/8"

THE RECIPIENT OF THIS DOCUMENT AGREES NOT TO REPRODUCE, COPY, TRANSMIT OR USE THIS DOCUMENT AND/OR THE INFORMATION CONTAINED IN THIS DOCUMENT IN WHOLE OR IN PART, FOR ANY PURPOSE, EXCEPT WITH THE WRITTEN PERMISSION OF VIBRA SCREW INCORPORATED.

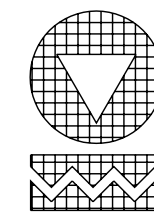

Vibra Screw Incorporated

755 Union Blvd.

Totowa, N.J. 07512-2207

TITLE

5'-0" DIA. BIN DISCHARGER
WITH GREASED VIBRATOR

DWN / DATE:

FP 06/03/99

DWG. NO.

17798-SD

REV. NO.

1

CAD FILE NAME

N:\BA\BD\STDASSY\17798-SD

NOTES:

- 1 - CONTACT MATERIAL: CARBON STEEL, 304 S/S, 316 S/S.
- 2 - VIBRATOR DRIVE TO BE: T.E.N.V., 1750 RPM, 230-460/3/60.
- 3 - ALL ELECTRICAL CONNECTIONS TO BE FLEXIBLE
- 4 - ALL CONNECTIONS TO BIN DISCHARGER MUST BE FLEXIBLE