

SECTION A-A

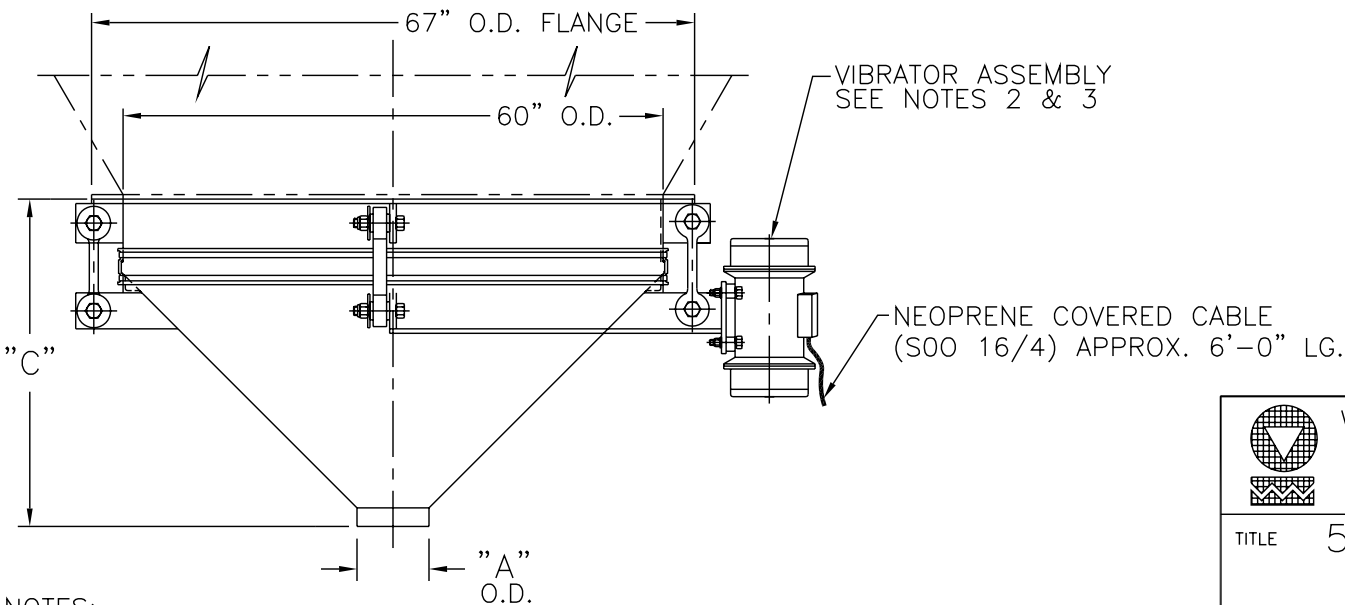

"A" O.D.	"C"
8" O.D.	36 3/8"
10" O.D.	35 3/8"
12" O.D.	34 3/8"
14" O.D.	33 3/8"

THE RECIPIENT OF THIS DOCUMENT AGREES NOT TO REPRODUCE, COPY, TRANSMIT OR USE THIS DOCUMENT AND/OR THE INFORMATION CONTAINED IN THIS DOCUMENT IN WHOLE OR IN PART, FOR ANY PURPOSE, EXCEPT WITH THE WRITTEN PERMISSION OF VIBRA SCREW INCORPORATED.

NOTES:

- 1 - CONTACT MATERIAL: CARBON STEEL, 304 S/S, 316 S/S.
- 2 - VIBRATOR DRIVE TO BE: 1 1/2 HP, T.E.N.V., 1750 RPM, 230-460/3/60
- 3 - ALL ELECTRICAL CONNECTIONS TO BE FLEXIBLE
- 4 - ALL CONNECTIONS TO BIN DISCHARGER MUST BE FLEXIBLE



Vibra Screw Incorporated

755 Union Blvd. Totowa, N.J. 07512-2207

TITLE 5'-0" DIA. BIN DISCHARGER
CENTER FLAT STOCK
AND GREASED VIBRATOR

DWN / DATE:
MJM 8/21/01

CAD FILE NAME
N:\BA\BD\STDASSY\17974-SD

DWG. NO.

17974-SD

REV. NO.

0