

VIBRA SCREW VIBRATING FEEDERS / CONVEYORS & SCREENERS

Simple and Efficient Equipment to Meter and Convey Dry Bulk Materials



Vibra Screw® Inc.

TRAY, TUBE, SPIRAL and SCREENER FEEDER / CONVEYORS

To handle virtually any material

Vibra Screw's line of vibrating feeder / conveyors offers a simple and efficient means to meter and convey your dry bulk materials. These open or closed units will handle nearly any material, regardless of size and bulk density in a reliable and economical manner.

Maintenance-free Operation

The key to the line's success is its low cost and unparalleled simplicity and efficiency. No moving parts ever touch the materials. There are no augers, bearings, seals or other items that might degrade material or require replacement or maintenance.

Two highly efficient, externally mounted vibrators provide quiet, linear motion to smoothly move your product into the process. Vibra Screw's feeder/conveyors are an excellent alternative to screw and belt feeders and conveyors.

Control Options

Vibra Screw offers feeder/conveyors normally set for a single rate. You achieve rate adjustability by varying the eccentric force of the vibrators. For applications requiring wider, more frequent rate changes, a motor speed controller is recommended.

Wide Range of Models

Vibra Screw offers standard feeder/conveyors with enclosed tubes or open troughs. Tube feeders are available up to 20ft in length and can be connected in series for lengths up to 100 ft. Trough feeders are also ideal applications requiring screening, classification and dewatering with addition of appropriate wire mesh decks. Trough feeders are also often used to spread out materials in a uniform layer.

Special Feeders

Special spiral elevating conveyors lift materials vertically up to 20 ft within a very small horizontal area. All vibrating feeder/conveyors are well suited to batching applications due to their characteristic quick cut-off of material flow. This can be further enhanced with an available dynamic motor brake.



Vibratory Tube Conveyor



Vibratory Screener High Temperature Design



Portable Vibratory Screener and Live Bottom Bin Package

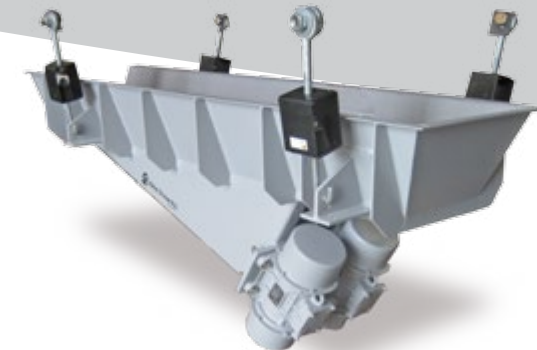

Vibratory Tray Conveyor with suspension hangers



Vibratory Tray Conveyor with Overhead Drives

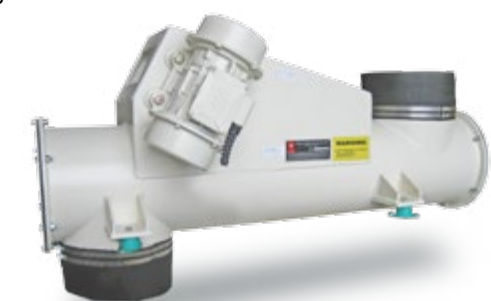

Vibratory Tube Conveyor with Overhead Drives



Sanitary Enclosed Vibratory Tray Conveyor

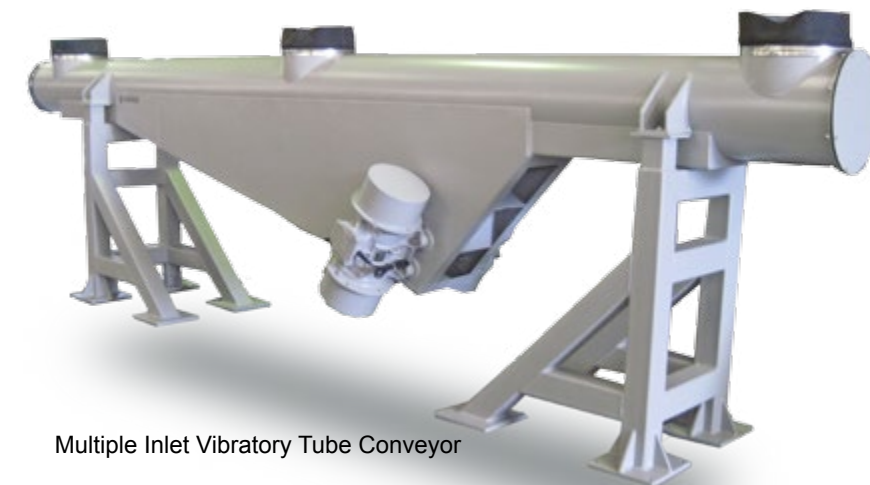

Multiple Inlet Vibratory Tube Conveyor

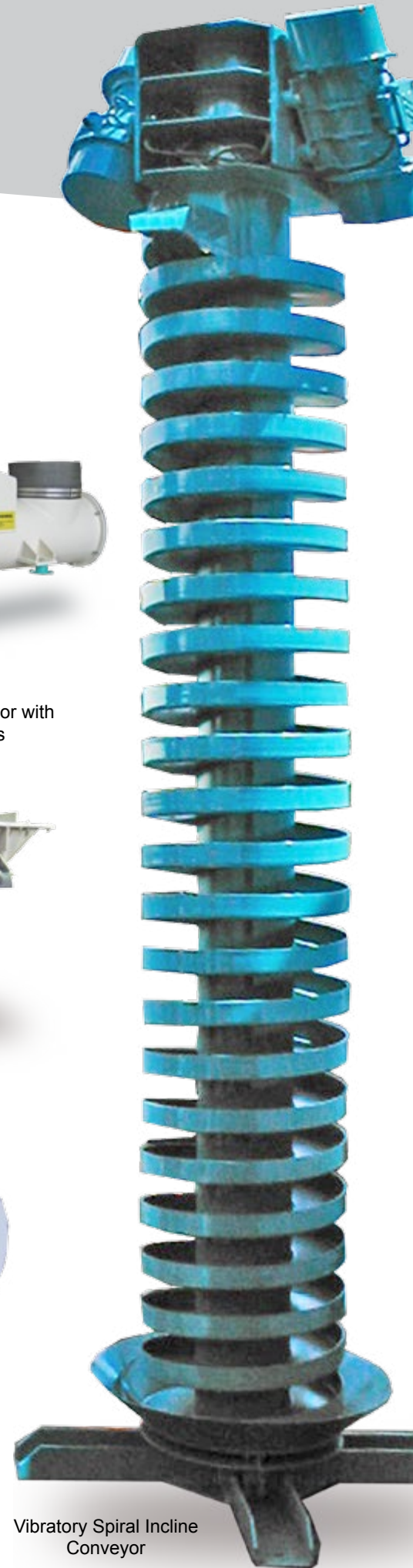

Vibratory Spiral Incline Conveyor

VIBRATORY TUBE CONVEYORS

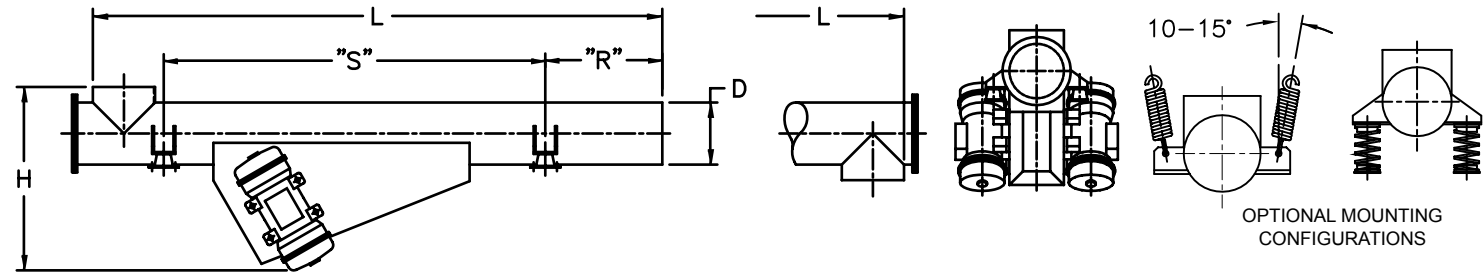

TUBULAR MODEL	CAPACITY TPH (CFH)	DIM - INCHES DxLxH	TOTAL HP (KW)	"R"	"S"
GA750/160-U1Y	7.9 (158)	6x30x19	0.25 (0.19)	6 3/4"	19 3/4"
GA1000/160-U1Y	7 (140)	6x40x19	0.25 (0.19)	12"	23 3/4"
GA1250/160-U1Y	6 (120)	6x50x19	0.25 (0.19)	13 3/4"	31 1/2"
GA1000/200-U2Y	15 (300)	8x40x21	0.36 (0.27)	12"	23 3/4"
GA1250/200-U2X	14 (280)	8x50x21	0.36 (0.27)	13 3/4"	31 1/2"
GA1500/200-U4X	26 (529)	8x60x21	0.62 (0.46)	15 3/4"	39 1/2"
GA2000/200-U4X	24 (475)	8x80x21	0.62 (0.46)	19 3/4"	55"
GA1250/260-U4X	42 (847)	10x50x23	0.62 (0.46)	13 3/4"	31 1/2"
GA1500/260-U4X	44 (880)	10x60x23	0.62 (0.46)	15 3/4"	39 1/2"
GA1750/260-U4X	40 (810)	10x70x25	0.62 (0.46)	17 3/4"	47 1/4"
GA2000/260-U4X	37 (740)	10x80x25	0.62 (0.46)	19 3/4"	55"
GA3000/260-U4X	49 (988)	10x120x26	0.62 (0.46)	23 3/4"	82 3/4"
GA4000/260-U6X	42 (847)	10x160x26	0.81 (0.60)	31 3/4"	106 1/4"
GA5000/260-U10X	44 (188)	10x200x26	1.5 (1.12)	35 1/2"	136"
GA6000/260-U10X	42 (847)	10x240x26	1.5 (1.12)	39 1/2"	165 1/2"
GA1500/320-U4X	49 (988)	12x60x31	0.62 (0.46)	15 3/4"	39 1/2"
GA2000/320-U6X	76 (1500)	12x80x32	0.81 (0.60)	19 3/4"	55"
GA3000/320-U10X	81 (1600)	12x120x32	1.5 (1.12)	23 3/4"	82 3/4"
GA4000/320-U10X	78 (1550)	12x160x33	1.5 (1.12)	31 3/4"	106 1/4"
GA5000/320-U16X	79 (1588)	12x200x32	1.68 (1.25)	35 1/2"	136 3/4"
GA6000/320-U25X	85 (1690)	12x240x32	2.5 (1.88)	39 1/2"	165 1/2"
GA1500/400-U6X	95 (1900)	16x60x38	0.81 (0.60)	17 3/4"	39 1/2"
GA2000/400-U10X	114 (2295)	16x80x38	1.5 (1.12)	19 3/4"	55"
GA3000/400-U10X	61 (1218)	16x120x42	1.5 (1.12)	23 3/4"	82 3/4"
GA4000/400-U16X	114 (2295)	16x160x42	1.68 (1.25)	31 3/4"	106 1/4"
GA5000/400-U25X	120 (2400)	16x200x42	2.5 (1.88)	35 1/2"	136 3/4"
GA6000/400-U25X	114 (2295)	16x240x42	2.5 (1.88)	39 1/2"	165 1/2"

Capacity: Selection based on:

- Material being 100 lb/ft³ density
- Horizontal positioning

- Voltage = 230-460/3/60
- Feed rate controller available
- Carbon or stainless steel contact parts, carbon steel external parts
- vibration isolators available as coil spring or rubber pad, compression or tension mounting
- Unbalanced vibratory drives as shown
- Controlability by variable frequency controller offering stepless variable output
- Dimensions stated nominal and are not to be used for construction purposes.

VIBRATORY TRAY CONVEYORS

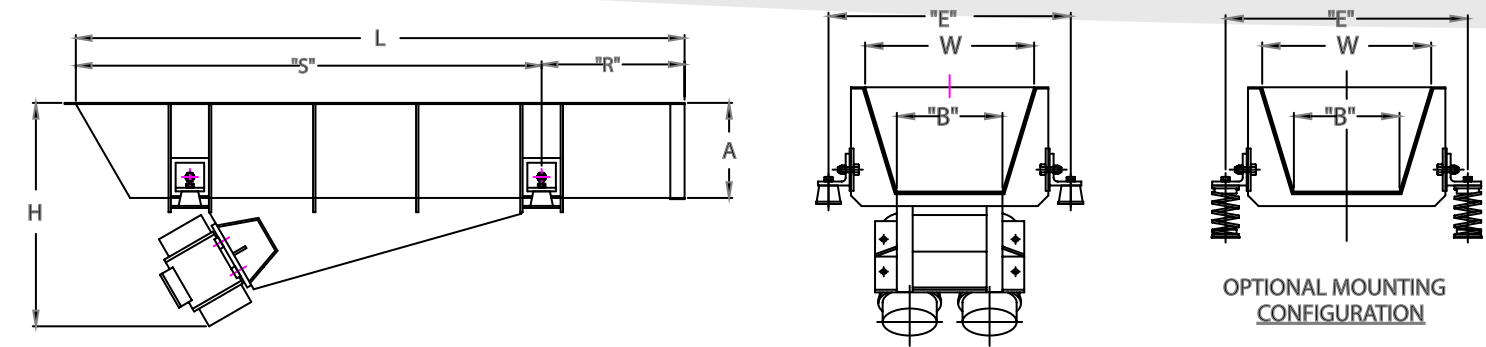

OPEN TROUGH MODEL	CAPACITY TPH (CFH)	DIM - INCHES DxLxHxA	TOTAL HP (KW)	WT LBS
OA500/300-U1Y	34 (670)	20x12x16x10	0.37 (0.28)	59
OA750/400-U1Y	19 (388)	29x16x16x10	0.37 (0.28)	79
OA1000/300-U1Y	19 (388)	40x12x18x10	0.37 (0.28)	81
OA1000/400-U1Y	18 (353)	40x16x18x10	0.37 (0.28)	88
OA1000/500-U2Y	55 (1,095)	40x20x18x10	0.62 (0.46)	103
OA1250/400-U3Y	62 (1,236)	49x16x19x10	0.62 (0.46)	158
OA1250/500-U4X	155 (3,107)	49x20x25x10	1 (0.74)	277
OA1250/650-U4X	169 (3,390)	49x25x25x10	1 (0.74)	299
OA1500/900-U4X	161 (3,213)	49x35x26x10	1 (0.74)	339
OA1250/500-U4X	125 (2,507)	59x20x26x10	1 (0.74)	330
OA1250/650-U4X	124 (2,472)	59x20x28x10	1 (0.74)	374
OA1500/900-U6X	212 (4,237)	59x35x29x10	1.37 (1.02)	484
OA1750/400-U4X	95 (1,907)	68x16x26x10	1 (0.74)	330
OA1750/650-U4X	109 (2,189)	68x25x28x10	1 (0.74)	396
OA1750/900-U6X	185 (3,708)	68x35x30x10	1.37 (1.02)	517
OA2000/500-U4X	92 (1,836)	80x20x30x10	1 (0.74)	396
OA2000/900-U6X	155 (3,107)	80x35x30x10	1.37 (1.02)	550
OA2500/400-U4X	72 (1,448)	98x16x28x10	1 (0.74)	385
OA2500/900-U6X	118 (2,366)	98x35x30x10	1.37 (1.02)	594
OA3000/400-U6X	111 (2,225)	117x16x30x10	1.37 (1.02)	440
OA3000/900-U10X	169 (3,390)	117x35x40x10	2.2 (1.66)	792
OA4000/400-U10X	97 (1,942)	156x16x33x10	2.2 (1.66)	671
OA4000/650-U25X	194 (3,884)	156x25x38x10	4 (3)	1,628
OA4000/900-U23W	274 (5,473)	156x35x40x10	4.5 (3.34)	1,861
OA4000/1600-U35W	512 (10,240)	156x62x43x10	6 (4.6)	2,809
OA5000/400-U16X	124 (2,472)	195x16x33x10	3 (2.2)	869
OA5000/650-U25X	168 (3,354)	195x25x33x10	4 (3)	1,804
OA5000/900-U37W	291 (5,826)	195x35x41x10	9 (6.6)	2,094
OA5000/1600-U53W	565 (11,299)	195x156x47x10	7 (5.48)	3,997
OA6000/500-U25X	132 (2,648)	234x20x38x10	4 (3)	1,628
OA6000/650-U37X	221 (4,414)	234x25x41x10	9 (6.6)	2,006
OA6000/900-U37X	256 (5,120)	234x35x41x10	9 (6.6)	2,325
OA6000/1600-U71W	618 (12,359)	234x156x49x10	10 (7.74)	4,730

Dimensions stated nominal and are not to be used for construction purposes.

VIBRATORY SCREENERS

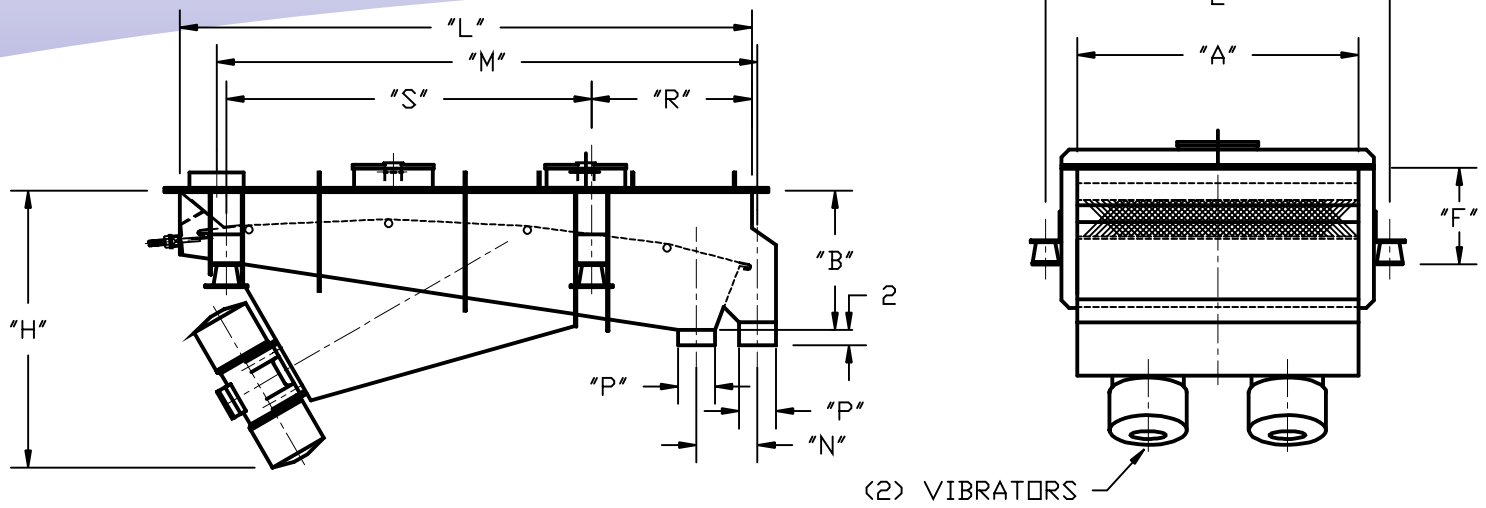

MODEL	SCREEN SURFACE AREA	TOTAL HP (KW)	"L"	"A"	"B"	"E"	"F"	"H"	"M"	"N"	"P"	"R"	"S"
VSB 300/1000-U2.2X	2.69	0.44 (0.33)	39 3/8"	12"	11"	19"	7 7/8"	25"	37 1/2"	6"	3"	9 1/2"	25 1/2"
VSB 400/1000-U2.2X	3.55	0.44 (0.33)	39 3/8"	16"	11"	23"	7 7/8"	25"	37 1/2"	6"	3"	9 1/2"	25 1/2"
VSB 400/1250-U4X	4.63	0.62 (0.46)	49 1/4"	16"	12"	23"	7 7/8"	27 1/2"	47 1/4"	6"	3"	12 3/4"	12 3/4"
VSB 500/1250-U4X	5.81	0.62 (0.46)	49 1/4"	20"	12"	27"	7 7/8"	27"	47 1/4"	6"	3"	12 3/4"	12 3/4"
VSB 500/1500-U6X	6.99	0.62 (0.46)	59"	20"	14"	28"	9 7/8"	28"	57"	7"	3 1/2"	15 3/8"	15 3/8"
VSB 650/1500-U6X	9.15	0.81 (0.60)	59"	25 1/2"	14"	34"	9 7/8"	34"	57"	7"	3 1/2"	17 3/4"	17 3/4"
VSB 650/1750-U6X	10.98	0.81 (0.60)	69"	25 1/2"	16"	34"	11 1/2"	34"	67"	8"	4"	17 3/4"	17 3/4"
VSB 650/2000-U10X	12.48	1.5 (1.12)	79"	25 1/2"	18"	34"	11 1/2"	34"	76 3/4"	10"	4 3/4"	17 3/4"	17 3/4"
VSB 900/1750-U10X	15.17	1.5 (1.12)	69"	35 1/2"	16"	34"	11 1/2"	34"	67"	7"	4"	17 3/4"	17 3/4"
VSB 900/2000-U16X	18.29	1.69 (1.25)	79"	35 1/2"	18"	44 1/2"	12 1/2"	44 1/2"	76 3/4"	10"	4 3/4"	17 3/4"	17 3/4"
VSB 900/2250-U16X	19.58	1.69 (1.25)	89"	35 1/2"	21"	44 1/2"	13 3/4"	44 1/2"	86 5/8"	10"	4 3/4"	17 3/4"	17 3/4"
VSB 1200/2250-U25X	26.04	2.5 (1.86)	89"	47 1/4"	21"	58"	13 3/4"	58"	86 5/8"	10"	4 3/4"	17 3/4"	17 3/4"

Dimensions stated nominal and are not to be used for construction purposes.

SPIRAL CONVEYORS

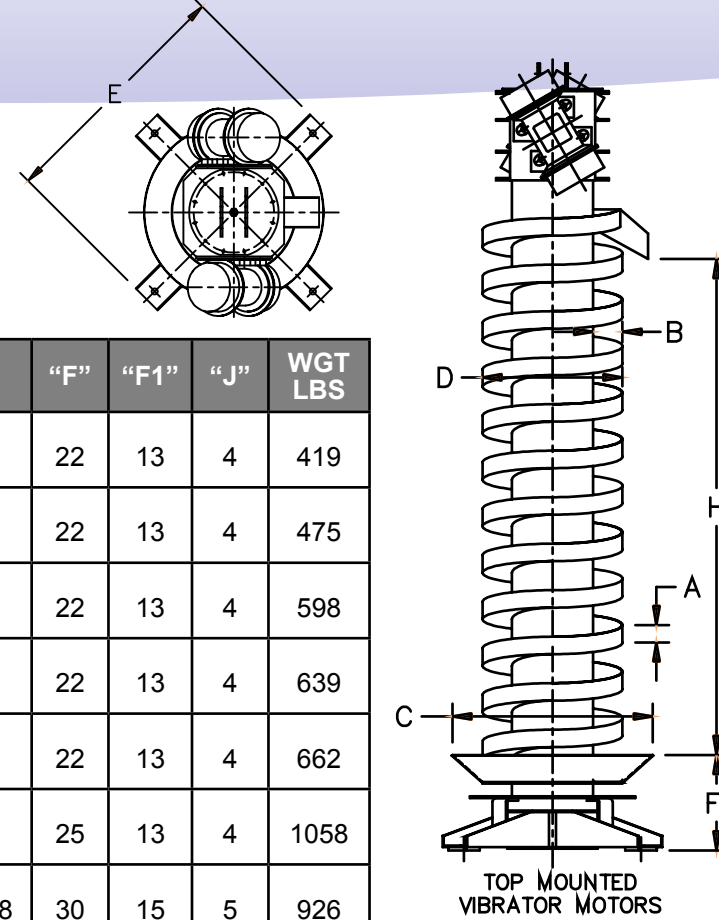

MODEL	RATE FT ³ /HR	"H"	"D"	"A"	"B"	"C"	"E"	"F"	"F1"	"J"	WGT LBS
WF1000/340-U4X	67	40	14	2	2 11/16	21	32	22	13	4	419
WF1500/340-U4X	67	60	14	2	2 11/16	21	32	22	13	4	475
WF2500/340-U4X	67	99	14	2	2 11/16	21	32	22	13	4	598
WF3000/340-U6X	67	118	14	2	2 11/16	21	32	22	13	4	639
WF3500/340-U6X	67	138	14	2	2 11/16	21	32	22	13	4	662
WF5000/340-U11X	67	197	14	2	2 11/16	21	32	25	13	4	1058
WF1500/560-U10X	141	60	22	3	4 5/8	32	43 3/8	30	15	5	926
WF2000/560-U10X	141	79	22	3	4 5/8	32	43 3/8	30	15	5	992
WF2500/560-U10X	141	99	22	3	4 5/8	32	43 3/8	30	15	5	1080
WF3000/560-U10X	141	118	22	3	4 5/8	32	43 3/8	30	15	5	1180
WF5000/560-U11X	141	197	27	3	4 5/8	32	43 3/8	35	15	5	1918
WF2000/680-U16W	247	79	27	4	7 1/8	38	47 1/4	35	15	6	1433
WF3000/680-U18W	247	118	27	4	7 1/8	38	47 1/4	35	15	6	1720
WF5000/680-U18W	282	197	27	4	7 1/8	38	47 1/4	38	15	6	2536
WF6000/680-U18W	282	237	27	4	7 1/8	38	47 1/4	38	15	6	2822
WF2000/900-U35W	459	79	35	5	7 1/2	44	52	45	18	9	2646
WF 3000/900-U35W	459	118	35	5	7 1/2	44	52	45	18	9	3153
WF 5000/900-U53W	388	197	35	5	7 1/2	44	52	45	18	9	4564
WF 6000/900-U53W	388	237	35	5	7 1/2	44	52	45	18	9	5116
WF 7000/900-U53W	388	276	35	5	7 1/2	44	52	45	18	9	5623

Dimensions stated nominal and are not to be used for construction purposes.

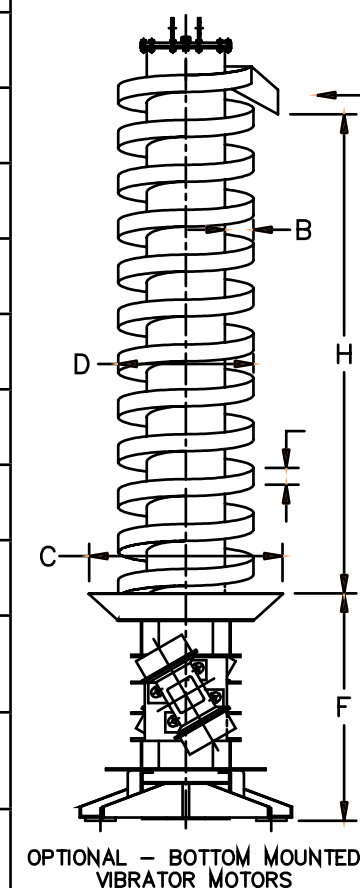

Keeping Dry Materials Moving

With a wealth of knowledge and experience in the use of controlled vibration to process dry bulk materials, Vibra Screw engineers have devised systems to handle most materials -- probably your material included.

As the leader in dry solids processing, our name is recognized and trusted worldwide in such diverse industries as:

FOODS

Flour, Soy, Meal, Sugar, Vitamin Supplements

MINING

Aggregate, Kiln Feed, Crushed Ores, Coal, Lime

CHEMICAL

Pigments, Additives, Starch, Carbon Black

STEEL

Foundry Sand, Ores, Binders, Ferrous & Non-Ferrous Additives

FOREST PRODUCTS

Chips, Sawdust, Waste-by-products

PLASTICS

Regrind, Virgin, Colorant, Talc

ENVIRONMENTAL CONTROL

Filter Aids, Resource Recovery, Lime, Soda Ash, Activated Carbon, Fly Ash, Solid Wastes, Scrap

ORDNANCE

Ammonium Nitrate, Oxidizing Salts, Solid Base Propellants, Ammonium Perchlorate, HMX, RDX

AGRICULTURE

Cattle Feed, Soy Bean Meal, Nutritional Supplements, Mill Feed, Spent Grain

PHARMACEUTICALS

Calcium Carbonate, Aspirin, Sodium Bicarbonate, Ascorbic Acid



VIBRA SCREW INC.
755 Union Blvd , Totowa, NJ 07512
Ph: 973-256-7410 Fax: 973-256-2114
www.VibraScrew.com

The Vibra Screw Product Line

For additional information, ask for literature on the following:

- AccuFeed
- Batching Systems
- Bin Activator
- Bulk Bag Filler
- Bulk Bag Unloader
- DE Feeder
- Heavy Duty Screw Feeder
- Loss-In-Weight Feeder
- Live Bottom Bin
- Live Bin
- Live Bin Screw Feeder
- Pan & Tube feeder
- Portable Bin Unloader
- Screener
- Storage Pile Activator
- VersiFeeder
- Vibra-Blender
- Vibrating Screens
- Volumetric Belt Feeder
- Weigh Belt Feeder
- Water Treatment Systems

THE VIBRA SCREW GUARANTEE

If your Vibra Screw equipment doesn't perform in the service for which it was sold, we'll refund your money. Ask any other equipment manufacturer to put that in writing.

No time limits. No conditions.